

### MGT For Parting Off

The new MGT Parting range is the 1st choice system for high performance parting applications, providing the best possible insert for the given operation. All MGT parting inserts fit into standard MGT external grooving holders (MGEHR/L).

- Different lead angles for different operations
  - 0° - Neutral for solid bar. Prevention of deflection on deep parting operations.
  - 4° - Pipe (tubing & hollow bar). Reduced burr.
  - 6° - Pipe & solid bar. Reduced burr on pipe and reduced pip on solid bar
  - 8° - Solid bar. Reduced pip.
  - 15° - Small diameter solid bar. Reduced burr and pip.

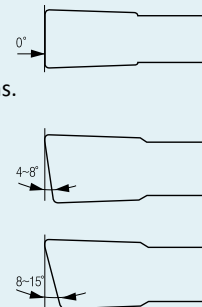

### MGT For Turning & Grooving

The MGT external holders (MGEHR/L) can be used for side-turning, grooving and profiling with inserts available from 1.5mm-8mm and tools from 10mm shank to 32mm shank.

- Different geometry inserts: MGMN (small radius) MRMN & MRGN (full radius)
- The standard MGT insert provides a 'wider' effect for improved surface finish.
- THE MINIMUM Depth of cut should not exceed the insert's nose radius
- The MAXIMUM depth of cut depends on the machine's cutting load capabilities.

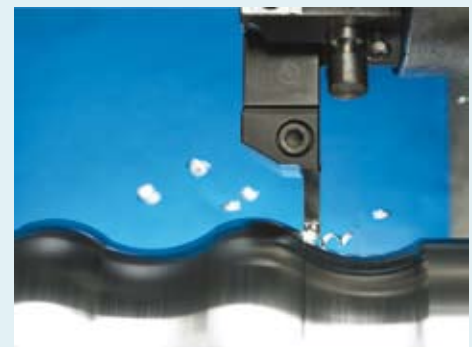

### Wide Grooving

An important benefit of the MGT tool is the ability to machine between wall. Follow a line of continuous machining. When most of the material is machined pull back the tool to profile.

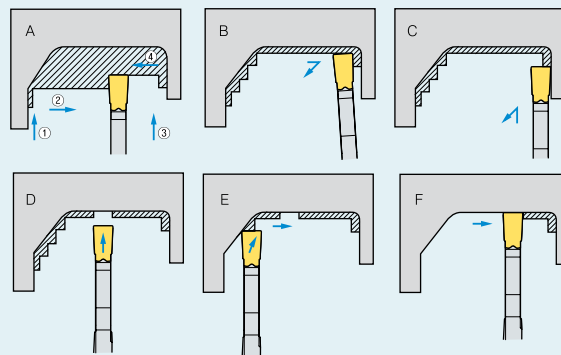

### MGT For Internal Machining

The MGT internal holders (MGIVR/L) can be used for internal grooving and profiling with the same inserts as the external tool holders from 16mm shank to 40mm shank. For smaller bore sizes please see the FINE TOOL range for minimum bore sizes starting at 8mm.

### MGT For Facial Grooving

The extended facial grooving range provides holders for every application, from small & shallow inside diameters to deep or wide outside diameters. The MGT range is available in 5 styles of holders.



### Parting Off - Recommended Cutting Conditions

Workpiece	Speed (m/min)							Feed (mm/rev) by cutting width (mm)				
	NC3120	NC3030	PC9030	PC230	NC6010	PC3525	H01	2	3	4	5	6
Steels	70~180	70~150		70~150		70~150		0.02~0.15	0.03~0.2	0.08~0.3	0.10~0.4	0.12~0.5
Stainless steels & Exotics			60~140					0.02~0.1	0.03~0.15	0.08~0.25	0.1~0.35	0.12~0.40
Cast iron					50~100			0.05~0.12	0.1~0.25	0.1~0.30	0.1~0.35	0.1~0.40
Non-ferrous metals							200~450	0.05~0.1	0.05~0.2	0.05~0.25	0.05~0.30	0.05~0.35

### Face Grooving - Recommended Cutting Conditions

Workpiece	Speed (m/min)							Feed (mm/rev) by cutting width (mm)		
	NC3120	NC3030	PC9030	PC230	NC6010	PC3525	H01	3	4	5
Steels	80~200	80~180		80~180		80~180		0.03~0.2	0.08~0.3	0.10~0.4
Stainless steels & Exotics			60~150					0.03~0.15	0.08~0.25	0.1~0.35
Cast iron					120~150			0.1~0.25	0.1~0.30	0.1~0.35
Non-ferrous metals							200~800	0.05~0.2	0.05~0.25	0.05~0.30

### Grooving / Turning - Recommended Cutting Conditions

Workpiece	Speed (m/min)							Feed (mm/rev) by cutting width (mm)				
	NC3120	NC3030	PC9030	PC230	NC6010	PC3525	H01	1.5	2~2.5	3	4-5	6-8
Steels	80~200	80~180		80~200		80~180		0.04~0.08	0.05~0.08	0.05~0.1	0.05~0.12	0.05~0.15
Stainless steels & Exotics			60~140					0.04~0.09	0.05~0.10	0.05~0.12	0.05~0.12	0.05~0.15
Cast iron					50~100			0.04~0.08	0.05~0.08	0.05~0.1	0.05~0.1	0.05~0.12
Non-ferrous metals							150~400	0.05~0.15	0.05~0.15	0.08~0.15	0.08~0.15	0.10~0.20

### MGT Insert Selection

APPLICATION	Inserts	Designation	£	Grades							Dimensions (mm)					Configuration	Holders		
				NC3030	NC3120	PC9030	PC3525	NC6010	NC9025	H01	b	r	l	d	t				
FACE GROOVING		FGD 300R-03	£5.62	•								3	0.3	15	2.0	4.0		FGHH FGVH (D66)	
		FGD 400R-04	£5.81	•								4	0.4	15	3.0	4.5			
		FGD 500R-04	£6.06	•									5	0.4	15	4.0			5.0
FACE GROOVING		FMM 300R-03	£5.62	•								3	0.3	15	2.0	3.91		FGHH FGVH (D66)	
		FMM 400R-04	£5.81	•								4	0.4	15	3.0	3.96			
		FMM 500R-04	£6.06	•									5	0.4	15	4.0			4.42
FACE GROOVING		MFMN 300	£8.90		•					•		3	0.2	18	2	3		MGFHR/L MGFVR/L (D65)	
GROOVING		MGMN 150-G	£7.63		•	•						1.5	0.15	16	1.2	3.5		MGEHR/L MGIVR/L MGEVR/L (D64-D68)	
GROOVING, TURNING		MGMN 200-M	£7.63	•	•	•		•				2	0.2	16	1.2	3.5		MGEHR/L MGIVR/L MGEVR/L (D64-D68)	
		MGMN 250-M	£8.90		•	•						2.5	0.2	18.5	2	3.85			
		MGMN 300-02-M	£8.90						•				3	0.2	21	2.35			4.8
		MGMN 300-M	£8.90	•	•	•		•					3	0.4	21	2.35			4.8
		MGMN 400-02-M	£9.99										4	0.2	21	3.3			4.8
		MGMN 400-M	£9.99	•	•			•	•				4	0.4	21	3.3			4.8
		MGMN 500-M	£11.41	•	•				•				5	0.8	26	4.1			5.8
		MGMN 600-M	£12.18	•	•				•				6	0.8	26	5			5.8
MGMN 800-M	£14.47		•				•				8	0.8	31	6	6.5				
PARTING		MGMR 200-6D-PT	£7.63		•		•					2	0.2	16	1.6	3.6		MGEHR/L (D64)	
		MGMR 300-6D-PT	£8.90		•		•					3	0.2	21	2.35	4.8			
		MGMR 300-8D-PT	£8.90		•		•					3	0.2	21	2.35	4.8			
		MGMR 300-15D-PT	£8.90		•		•					3	0.2	21	2.35	4.8			
		MGMR 400-4D-PT	£9.99		•		•						4	0.3	21	3.3			4.8
MGMR 500-4D-PT	£11.41		•		•						5	0.3	26	4.1	5.8				
ALUMINIUM		MRGN 400-A	£9.99							•		4	2	21	3.3	3.3		MGEHR/L MGIVR/L MGEUR/L MGIUR/L MGEVR/L (D64-D68)	
		MRGN 500-A	£11.41							•		5	2.5	26	4.1	4.1			
		MRGN 600-A	£12.18							•		6	3	26	5	5			
		MRGN 800-A	£14.47							•		8	4	31	6	6			
PROFILING		MRMN 200-M	£7.63		•					•		2	1	16	1.5	3.5		MGEHR/L MGIVR/L MGEUR/L MGIUR/L MGEVR/L (D64-D68)	
		MRMN 300-M	£8.90	•	•					•		3	1.5	21	2.35	4.8			
		MRMN 400-M	£9.99	•	•					•		4	2	21	3.3	4.8			
		MRMN 500-M	£11.41	•	•					•		5	2.5	26	4.1	5.8			
		MRMN 600-M	£12.18	•	•					•		6	3	26	5	5.8			
		MRMN 800-M	£14.47	•	•					•		8	4	31	6	6.5			

Stock Status • Stock item (next day delivery) □ Non-stock item (7-10 days)

## MGT External MGEHR/L

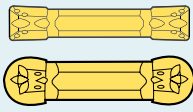

MGMN, MGMR  
MRMN, MRGN

For grooving, parting, turning, relieving, profiling & aluminium machining

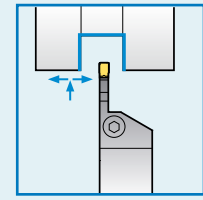
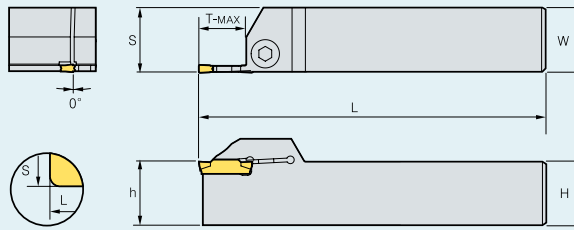

Designation	£	STOCK		H=(h)	W	L	S	T-MAX	Inserts	Screw	Wrench		
		R	L										
MGEHR/L	1010-X15A	£69.00	•	•	10	10	125	-	10	MGMN150-G (1.5mm)	ETNA0412	TW15L	
	1212-X15A	£69.00	•	•	12	12	125	-	12.5				
	1616-1.5	£59.00	•	•	16	16	100	16.25	14.5		LTX0514	TW20L	
	2020-1.5	£59.00	•	•	20	20	125	20.25	14.5				
	2525-1.5	£59.00	•	•	25	25	150	25.25	14.5				
	1010-X20A	£69.00	•	•	10	10	125	-	10	MGMN200 MRMN200 MGMR200 (2.0mm)	ETNA0412	TW15L	
	1212-X20A	£69.00	•	•	12	12	125	-	12.5				
	1212-2	£59.00	•		12	12	100	14.25	14.5		MHA0512	HW40L	
	1616-2	£59.00	•	•	16	16	100	16.25	14.5				
	2020-2	£59.00	•	•	20	20	125	20.25	14.5				
2525-2	£59.00	•	•	25	25	150	25.25	14.5					
	1010-X25A	£69.00	•	•	10	10	125	-	10	MGMN250 (2.5mm)	ETNA0412	TW15L	
	1212-X25A	£69.00	•	•	12	12	125	-	12.5				
	1616-2.5	£59.00	•	•	16	16	100	16.3	16.5		MHA0512	HW40L	
	2020-2.5	£59.00	•	•	20	20	125	20.3	16.5				
	2525-2.5	£59.00	•	•	25	25	150	25.3	16.5				
	1616-3	£59.00	•	•	16	16	100	16.35	18.5	MGMN300 MRMN300 MGMR300 (3mm)	BHA0616	HW50L	
	2020-3	£59.00	•	•	20	20	125	20.4	18				
	2525-3	£59.00	•	•	25	25	150	25.4	18				
	3232-3	£69.00	•	•	32	32	170	32.4	18				
	2020-4	£59.00	•	•	20	20	125	20.4	18				MGMN400 MRMN400 MGMR400 MRGN400 (4.0mm)
	2525-4	£59.00	•	•	25	25	150	25.4	18				
	3232-4	£69.00	•	•	32	32	170	32.4	18				
	2020-5	£59.00	•	•	20	20	150	20.5	23				
	2525-5	£59.00	•	•	25	25	150	25.5	23	MGMN500 MRMN500 MGMR500 MRGN400 (5.0mm)			
	3232-5	£69.00	•	•	32	32	170	32.5	23				
	2020-6	£59.00	•	•	20	20	125	20.6	23		MGMN600 MRMN600 MRGN600 (6.0mm)		
2525-6	£59.00	•	•	25	25	150	25.6	23					
3232-6	£69.00	•	•	32	32	170	32.6	23					
	2525-8	£59.00	•	•	25	25	150	26.1	28	MGMN800 MRMN800 MRGN800			
	3232-8	£69.00	•		32	32	170	33.1	28				

For inserts please see page D63

Stock Status    • Stock item (next day delivery)    □ Non-stock item (7-10 days)

## MGT Face Groove MGFHR



MGFN  
MGMN

For facial grooves up to 10mm deep - straight approach

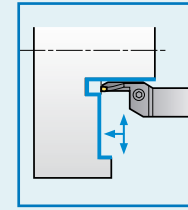
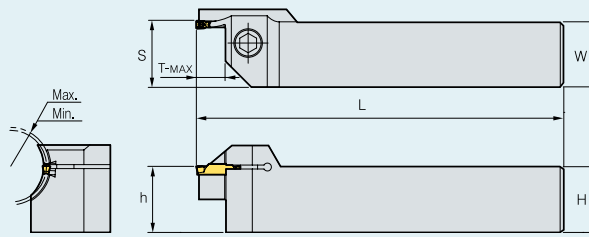

Right hand shown

Designation		£	H=(h)	W	L	S	T-MAX	Min.	Max.	INSERTS	SCREW	WRENCH
MGFHR/L	325-24/35-T10	£69.00	25	25	150	25.6	10	24	35	MFMN300 (3.0mm)	BHA0616	HW50L
	325-29/40-T10	£69.00	25	25	150	25.6	10	29	40			
	325-34/50-T10	£69.00	25	25	150	25.6	10	34	50			
	325-44/70-T10	£69.00	25	25	150	25.6	10	44	70			
	325-64/99-T10	£69.00	25	25	150	25.6	10	64	99			
	425-62/120-T15	£69.00	25	25	150	25.6	15	62	120	MGMN400-M (4.0mm)		
425-112/200-T15	£69.00	25	25	150	25.6	15	112	200				

## MGT Face Groove MGFVR

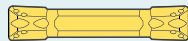

MGFN  
MGMN

For facial grooves up to 10mm deep - cranked approach

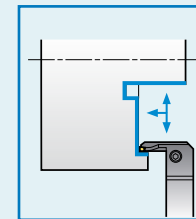
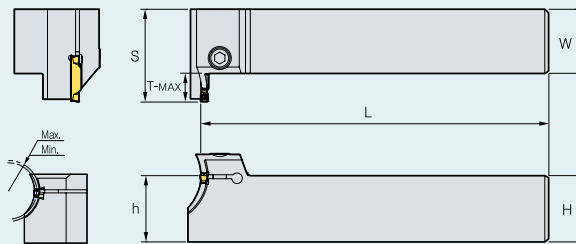

Right hand shown

Designation		£	H=(h)	W	L	S	T-MAX	Min.	Max.	INSERTS	SCREW	WRENCH
MGFVR/L	325-24/35-T10	£85.00	25	25	150	18	10	24	35	MFMN300 (3.0mm)	MHA0512	HW40L
	325-29/40-T10	£85.00	25	25	150	18	10	29	40			
	325-34/50-T10	£85.00	25	25	150	18	10	34	50			
	425-44/60-T15	£85.00	25	25	150	25	15	44	60	MGMN400-M		

For inserts please see page D63      Stock Status      • Stock item (next day delivery)      □ Non-stock item (7-10 days)

### Min/Max

The Min & Max column represents the minimum inside diameter that can be machined and the maximum outside diameter for the first plunge. Failure to machine within these parameters will result in tool failure.

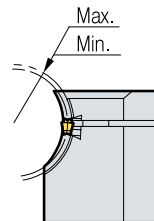

**MGT Face Groove  
FGHH/FGVH**

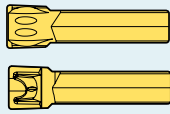

**FGD  
FMM**

For facial grooves up to 25mm deep

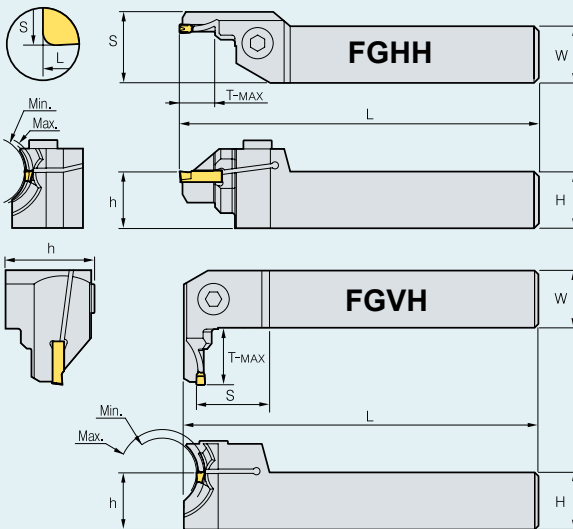

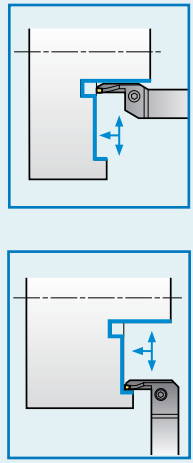

Right hand shown

LATHE TOOLS

Designation	£	H=(h)	W	L	S	T-MAX	Min.	Max.	INSERTS	SCREW	WRENCH
FGHH or FGVH	320R - 25/30	£79.00	20	20	125	20.6	12	25	30	FMM300R-03 (3mm)	BHA0616  HW50L
	320R - 30/35	£79.00	20	20	125	20.6	12	30	35		
	320R - 35/48	£79.00	20	20	125	20.6	12	35	48		
	325R - 25/30	£79.00	25	25	150	25.6	12	25	30		
	325R - 30/35	£79.00	25	25	150	25.6	12	30	35	FMM300R-03 (3mm)	
	325R - 35/48	£79.00	25	25	150	25.6	12	35	48		
	325R - 48/60	£79.00	25	25	150	25.6	22	48	60	FGD300R-03 (3mm)	
	325R - 60/75	£79.00	25	25	150	25.6	22	60	75		
	325R - 75/100	£79.00	25	25	150	25.6	22	75	100		
	325R - 100/140	£79.00	25	25	150	25.6	22	100	140		
	420R - 25/30	£79.00	20	20	125	20.6	12	25	30	FMM400R-04 (4mm)	
	420R - 30/35	£79.00	20	20	125	20.6	12	30	35		
	420R - 35/48	£79.00	20	20	125	20.6	12	35	48		
	425R - 25/30	£79.00	25	25	150	25.6	12	25	30	FMM400R-04 (4mm)	
	425R - 30/35	£79.00	25	25	150	25.6	12	30	35		
	425R - 35/48	£79.00	25	25	150	25.6	12	35	48	FGD400R-04 (4mm)	
	425R - 48/60	£79.00	25	25	150	25.6	25	48	60		
	425R - 60/75	£79.00	25	25	150	25.6	25	60	75		
	425R - 75/100	£79.00	25	25	150	25.6	25	75	100		
	425R - 100/140	£79.00	25	25	150	25.6	25	100	140	FMM500R-04 (5mm)	
520R - 25/30	£79.00	20	20	125	20.6	12	25	30			
520R - 30/35	£79.00	20	20	125	20.6	12	30	35			
520R - 35/40	£79.00	20	20	125	20.6	20	35	40			
520R - 40/48	£79.00	20	20	125	20.6	20	40	48	FMM500R-04 (5mm)		
525R - 25/30	£79.00	25	25	150	25.6	12	25	30			
525R - 30/35	£79.00	25	25	150	25.6	12	30	35	FGD500R-04 (5mm)		
525R - 35/40	£79.00	25	25	150	25.6	20	35	40			
525R - 40/48	£79.00	25	25	150	25.6	20	40	48			
525R - 48/60	£79.00	25	25	150	25.6	25	48	60			
525R - 60/75	£79.00	25	25	150	25.6	25	60	75	FGD500R-04 (5mm)		
525R - 75/100	£79.00	25	25	150	25.6	25	75	100			
525R - 100/140	£79.00	25	25	150	25.6	25	100	140			

MGT Series

For inserts please see page D63

Stock Status    ● Stock item (next day delivery)    □ Non-stock item (7-10 days)

**MGT Face Groove MGEVR/L**

For shallow facial grooves up to 7mm deep

**MGMN**

Right hand shown

Designation	£	STOCK		H=(h)	W	L	S	T-MAX	INSERTS	SCREW	WRENCH	
		R	L									
MGEVR/L	2020-1.5	£59.00	•		20	20	125	23	3	MGMN150 (1.5mm)	LTX0514	TW20L
	2525-1.5	£59.00	•		25	25	150	28	3			
	2020-2	£59.00	•		20	20	125	23.5	3.5	MGMN200 (2.0mm)	BHA0616	HW50L
	2525-2	£59.00	•		25	25	150	28.5	3.5			
	2020-2.5	£59.00	•		20	20	125	23.5	3.5	MGMN250 (2.5mm)		
	2525-2.5	£59.00	•		25	25	150	29	3.5			
	2020-3	£59.00	•		20	20	125	25.5	5	MGMN300 (3.0mm)		
	2525-3	£59.00	•	•	25	25	150	30.5	5			
	2020-4	£59.00	•		20	20	125	25.5	5	MGMN400 (4.0mm)		
	2525-4	£59.00	•	•	25	25	150	27	5			
	2020-5	£59.00	•		20	20	125	32	7	MGMN500 (5.0mm)		
	2525-5	£59.00	•	•	25	25	150	39	7			
2020-6	£59.00	•		20	20	125	32	7	MGMN600 (6.0mm)			
2525-6	£59.00	•		25	25	150	39	7				

**MGT Relief Groove MGEUR/L**

For external relief grooves

**MRMN MRGN**

Right hand shown

Designation	£	STOCK		H=(h)	W	L	S	T-MAX	INSERTS	SCREW	WRENCH	
		R	L									
MGEUR/L	2020-3	£59.00	•		20	20	125	23	3	MRMN300 (3mm)	BHA0616	HW50L
	2525-3	£59.00	•		25	25	150	28	3			
	2525-4	£59.00	•		25	25	150	28	3			

For inserts please see page D63      Stock Status    • Stock item (next day delivery)    □ Non-stock item (7-10 days)

**MGT Internal MGIVR/L**

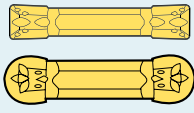

**MGMN  
MRMN  
MRGN**

For grooving, turning, relieving, profiling and aluminium machining

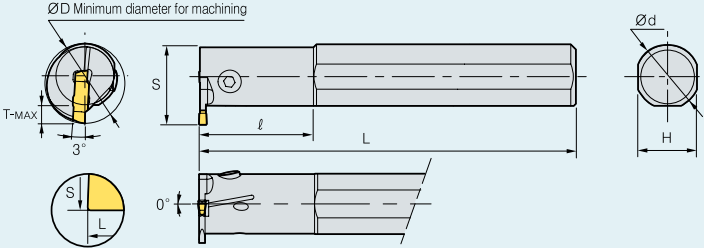

Right hand shown

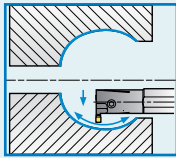

Designation	£	STOCK		ØD	Ød	L	ℓ	T-MAX	H	S	INSERTS	SCREW	WRENCH	
		R	L											
MGIVR/L	2016-1.5	£60.00	•		20	16	125	35	4	15	11.3	MGMN150 (1.5mm)	MHB0310	HW25L
	2520-1.5	£60.00	•		25	20	150	45	4	18	13.1		MHA0512	HW40L
	2925-1.5	£72.00	•		29	25	200	45	4	23	16.2	MGMN200 MRMN200 (2mm)	MHB0310	HW25L
	2016-2	£60.00	•	•	20	16	125	35	5	15	12.4		MHA0512	HW40L
	2520-2	£60.00	•	•	25	20	150	45	5	18	14		MHB0310	HW25L
	2925-2	£72.00	•	•	29	25	200	45	5	23	17.2	MGMN250 (2.5mm)	MHA0512	HW40L
	2016-2.5	£60.00	•		20	16	125	35	5	15	12.5		MHB0310	HW25L
	2520-2.5	£60.00	•		25	20	150	45	5	18	15.1	MGMN300 MRMN300 (3.0mm)	MHA0512	HW40L
	2925-2.5	£72.00	•		29	25	200	45	5	23	18.2		MHB0310	HW25L
	2520-3	£60.00	•	•	25	20	150	45	6	18	15.6	MGMN400 MRMN400 MRGN400 (4.0mm)	MHA0512	HW40L
	3125-3	£72.00	•	•	31	25	200	45	6	23	18.9			
	3732-3	£84.00	•		37	32	250	65	6	30	21.5			
	2520-4	£60.00	•	•	25	20	150	45	6	18	15.6	MGMN500 MRMN500 MRGN500 (5.0mm)	BHA0616	HW50L
	3125-4	£72.00	•		31	25	200	45	6	23	18.9			
	3732-4	£84.00	•		37	32	250	65	6	30	21.5	MGMN600 MRMN600 MRGN600 (6.0mm)	BHA0620	HW50L
	3125-5	£72.00	•		31	25	200	45	8	23	19.4			
3732-5	£84.00	•		37	32	250	65	8	30	21.5	MGMN800 MRMN800 MRGN800 (8.0mm)	BHA0616	HW50L	
3125-6	£72.00	•	•	31	25	200	45	8	23	19.4				
3732-6	£84.00	•		37	32	250	65	8	30	21.5	MGMN800 MRMN800 MRGN800 (8.0mm)	BHA0620	HW50L	
3732-8	£84.00	•		37	32	250	65	10	30	23.4				
4540-8	£115.00	•		45	40	300	70	10	37	27.2				

**MGT Relief Groove MGIUR/L**



**MRMN  
MRGN**

For internal relief grooves

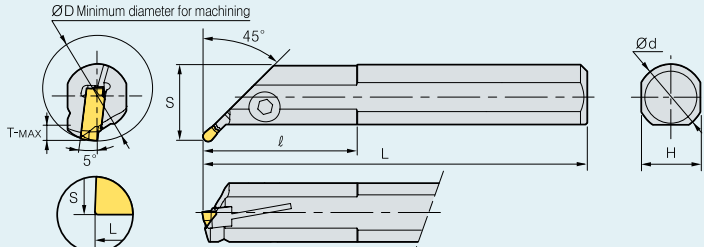

Right hand shown

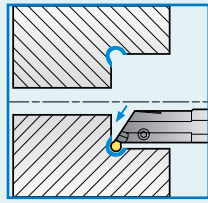

Designation	£	STOCK		ØD	Ød	L	ℓ	T-MAX	H	S	INSERTS	SCREW	WRENCH	
		R	L											
MGIUR/L	4025-3	£72.00	•		40	25	200	45	3.5	23	15.5	MRMN300 (3.0mm)	MHA0512	HW40L
	4025-4	£72.00	•		40	25	200	45	3.5	23	15.5	MRMN400 MRGN400 (4.0mm)		
	5032-4	£84.00	•		50	32	250	65	3.5	30	19			

For inserts please see page D63

Stock Status • Stock item (next day delivery) □ Non-stock item (7-10 days)