

### The Auto Tool Range

The Auto Tool range is designed for applications where size & precision matters. The inserts are precision ground to the highest tolerance for ultimate accuracy and are excellent for complicated machining.

The range comes on a variety of small shank sizes starting at 8mm making it ideal for Automatic lathes, sliding heads or any other machine where small shank tooling is required.

Auto Tools are available in the FGT style, ISO Turning, MGT Multi-Grooving Tools and Compact Mini Boring Bars.



- Excellent for precision machining
- Excellent for complicated machining
- Excellent for small part machining
- Various insert sizes and geometries can be clamped on one FGT holder
- ISO holders offset "0"

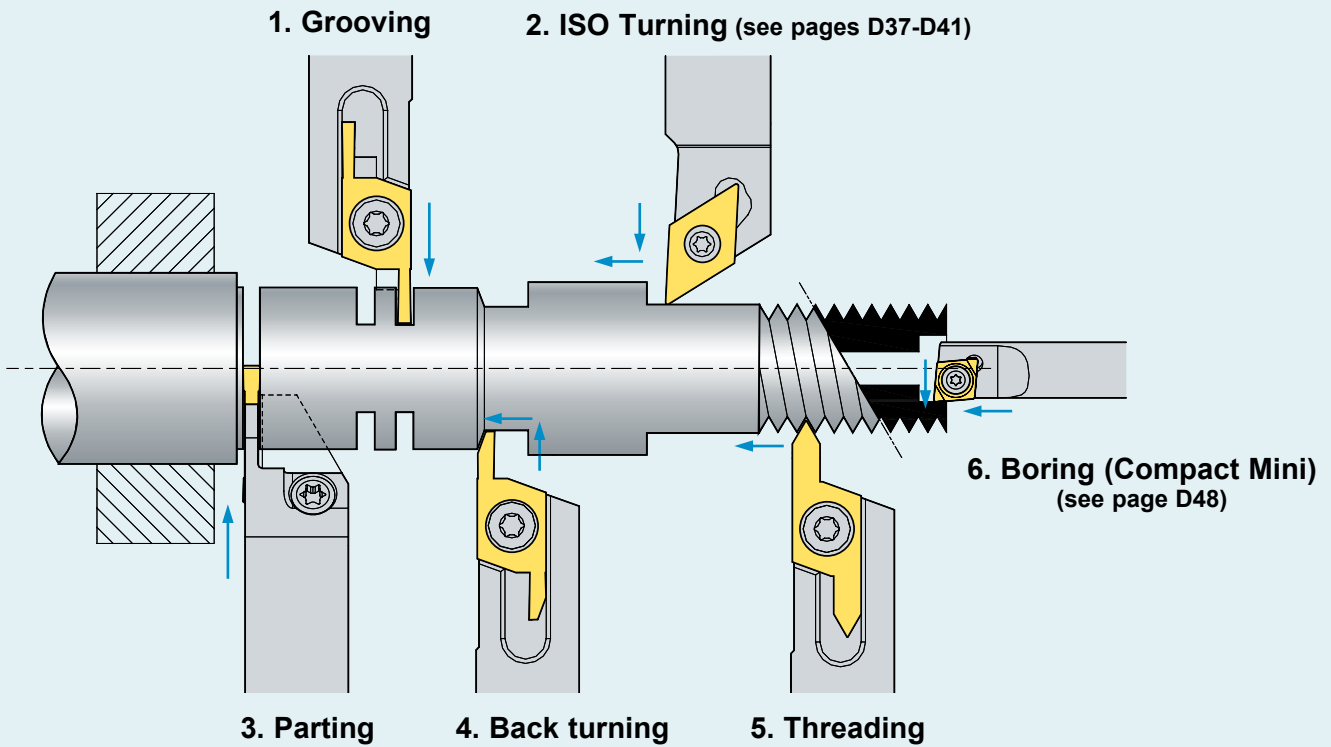

### Recommended Cutting Conditions

Workpiece	Turning		Grooving		Parting		Back Turning	
	Speed (m/min)	Feed (mm/rev)	Speed (m/min)	Feed (mm/rev)	Speed (m/min)	Feed (mm/rev)	Speed (m/min)	Feed (mm/rev)
Stainless steel	50~120	0.02~0.20	30~120	0.02~0.05	30~120	0.02~0.05	30~120	0.02~0.20
Carbon steel	50~150	0.01~0.25	50~150	0.02~0.08	50~150	0.02~0.08	50~150	0.01~0.25
Free-cutting steel	30~150	0.02~0.25	30~150	0.02~0.08	30~150	0.02~0.08	30~150	0.01~0.25
Non-ferrous metal	70~200	0.03~0.25	70~200	0.03~0.10	70~200	0.03~0.10	70~200	0.03~0.30

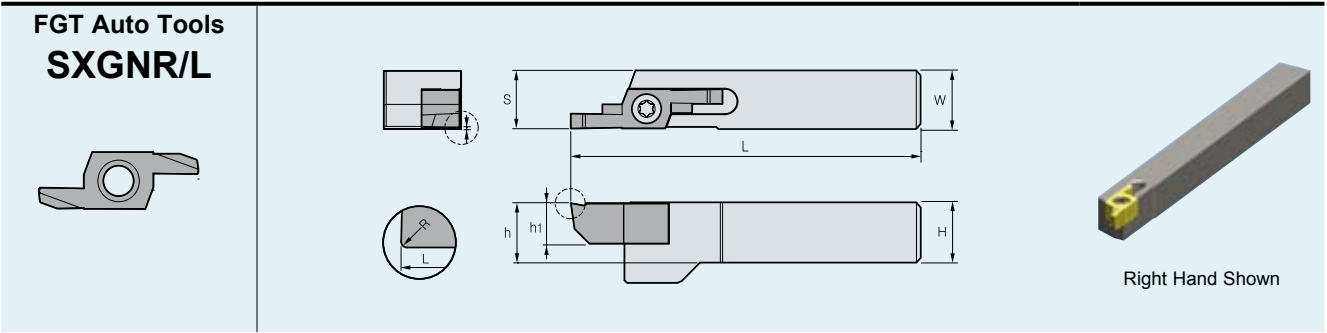

DESIGNATION	£	STOCK		H	W	L	S	H	ℓ	INSERT	SCREW	WRENCH	
		R	L										
SXGNR/L	1010-X06A	£49.00	•	•	10	10	125	10	10	6			
	1212-X06A	£49.00	•	•	12	12	125	12	12	6			
	1616-X06A	£49.00	•	•	16	16	125	16	16	6	S□R/L 06	FTNA 0409	TW 15P
	2020-X06A	£49.00	•	•	20	20	125	20	20	6			

Application	Designations	£	b	b1	W	L	r	h	T MAX	ØD	PITCH	Drawing	Feed Direction																																																																																																																																		
	SBR/L 060520-10-R05	£11.99	2	1	8	22	0.1	6	5.5	-	-																																																																																																																																				
	SBR/L 060530-20-R10	£11.99	3	2	8	24	0.1	6	6.5	-	-				SCR060610-R10	£11.99	1	-	8	24	0.1	6	-	11	-			SCR060615-R10	£11.99	1.5	-	8	24	0.1	6	-	11	-	SCR060620-R10	£11.99	2	-	8	24	0.1	6	-	11	-		SGR/L 060610-R10	£11.99	1	-	8	24	0.1	6	-	11	-			SGR/L 060615-R10	£11.99	1.5	-	8	24	0.1	6	-	11	-	SGR/L 060620-R10	£11.99	2	-	8	24	0.1	6	-	11	-		SGBR/L 0604520-R10	£11.99	2	-	8	22	0.1	6	5.5	-	-			SGBR/L 0604525-R10	£11.99	2.5	-	8	22	0.1	6	5.5	-	-	SGBR/L 0605530-R10	£11.99	3	-	8	24	0.1	6	6.5	-	-		STR/L 6073215	£11.99	3.2	-	8	25	0.06	6	7	-	0.5-1.5			STR/L 6073230	£11.99	3.2	-	8	25	0.19	6
	SCR060610-R10	£11.99	1	-	8	24	0.1	6	-	11	-																																																																																																																																				
	SCR060615-R10	£11.99	1.5	-	8	24	0.1	6	-	11	-																																																																																																																																				
	SCR060620-R10	£11.99	2	-	8	24	0.1	6	-	11	-																																																																																																																																				
	SGR/L 060610-R10	£11.99	1	-	8	24	0.1	6	-	11	-																																																																																																																																				
	SGR/L 060615-R10	£11.99	1.5	-	8	24	0.1	6	-	11	-																																																																																																																																				
	SGR/L 060620-R10	£11.99	2	-	8	24	0.1	6	-	11	-																																																																																																																																				
	SGBR/L 0604520-R10	£11.99	2	-	8	22	0.1	6	5.5	-	-																																																																																																																																				
	SGBR/L 0604525-R10	£11.99	2.5	-	8	22	0.1	6	5.5	-	-																																																																																																																																				
	SGBR/L 0605530-R10	£11.99	3	-	8	24	0.1	6	6.5	-	-																																																																																																																																				
	STR/L 6073215	£11.99	3.2	-	8	25	0.06	6	7	-	0.5-1.5																																																																																																																																				
	STR/L 6073230	£11.99	3.2	-	8	25	0.19	6	7	-	1.5-3.0																																																																																																																																				