

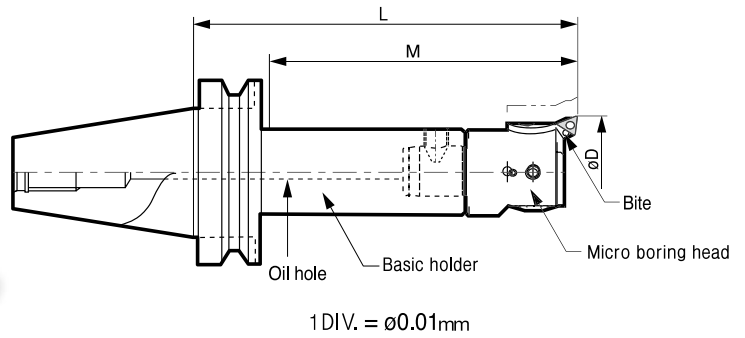

MICRO BORING BAR BT MAS Full System (MD-FBH)

Precision Micro Boring Systems For the Ultimate In Precision & Accuracy from ØD20-ØD150mm



- Fine adjusting system - 0.01mm graduations.
- Compact design and intensive functions can achieve H6/H7 tolerances.
- Wide boring ranges: ØD20mm-150mm.
- Different combinations not listed below are available through various length basic holders, extensions and reducers.
- Through coolant

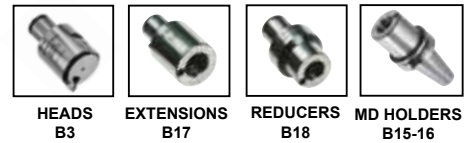

BT MAS (MD-FBH Series) Micro Boring System

Order Code (Basic Holder & Head)	£	Boring Range ØD		L	Max Boring Depth	Basic Holder	Micro Boring Head	Available Bites	kg
		Min	Max						
BT40-FBH20-103	£476.00	20	26	103	72	BT40-MD19F-70	FBH1920N	FBB20N-C	1.9
BT40-FBH26-133	£500.00	26	34	133	100	BT40-MD25F-95	FBH2526N	FBB26N-C	2
BT40-FBH33-141	£526.00	33	43	141	110	BT40-MD32F-100	FBH3233N	FBB33N-C	2.3
BT40-FBH42-162	£580.00	42	54	162	130	BT40-MD40F-115	FBH4042N	FBB42N-C	2.9
BT40-FBH53-162	£619.00	53	70	162	130	BT40-MD50F-105	FBH5053N	FBB53N-C	3.5
BT40-FBH68-181	£692.00	68	100	181	150	BT40-MD63F-110	FBH6368N	FBB68N-C	6.3
BT40-FBH98-206	£861.00	98	150	206	173	BT40-MD63F-135	FBH6398N	FBB68N-C	7.1
BT50-FBH20-118	£479.00	20	26	118	76	BT50-MD19F-85	FBH1920N	FBB20N-C	5.2
BT50-FBH26-142	£512.00	26	34	142	100	BT50-MD25F-105	FBH2526N	FBB26N-C	5.8
BT50-FBH33-151	£540.00	33	43	151	109	BT50-MD32F-110	FBH3233N	FBB33N-C	6
BT50-FBH42-192	£598.00	42	54	192	150	BT50-MD40F-145	FBH4042N	FBB42N-C	6.3
BT50-FBH42-242	£607.00	42	54	242	200	BT50-MD40F-195	FBH4042N	FBB42N-C	6.6
BT50-FBH53-182	£634.00	53	70	182	140	BT50-MD50F-125	FBH5053N	FBB53N-C	6.9
BT50-FBH53-282	£656.00	53	70	282	240	BT50-MD50F-225	FBH5053N	FBB53N-C	7.2
BT50-FBH68-201	£701.00	68	100	201	159	BT50-MD63F-130	FBH6368N	FBB68N-C	8.1
BT50-FBH68-301	£728.00	68	100	301	260	BT50-MD63F-230	FBH6368N	FBB68N-C	8.5
BT50-FBH98-211	£868.00	98	150	211	169	BT50-MD63F-140	FBH6398N	FBB68N-C	8.9

Build Your Own Modular System.....

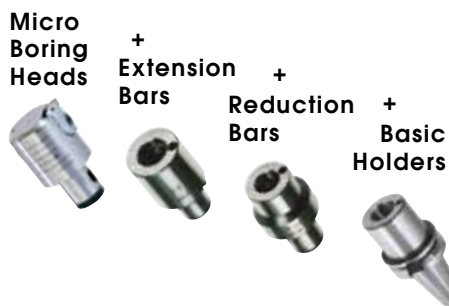

(MD-FBH Series) Micro Boring Bites

Order Code	£	Insert
FBB20N-C	£46.00	CCET0401øøL
FBB26N-C	£46.00	CCET0401øøL
FBB33N-C	£46.00	CCMT0602øø, CCGT0602øøL
FBB42N-C	£51.00	CCMT0602øø, CCGT0602øøL
FBB53N-C	£51.00	CCMT0602øø, CCGT0602øøL
FBB68N-C	£55.00	CCMT09T3øø, CCGT09T3øøL
FBB20N	£46.00	TPGT0802øøL, TPGW0802øø
FBB26N	£46.00	TPGT0802øøL, TPGW0802øø
FBB33N	£46.00	TPGT0802øøL, TPGW0802øø



DIN69871 Full System (MD-FBH) MICRO BORING BAR



Precision Micro Boring Systems For the Ultimate In Precision & Accuracy from $\varnothing D20$ - $\varnothing D150$ mm

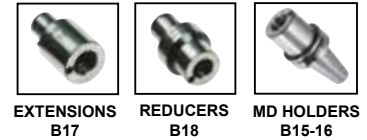
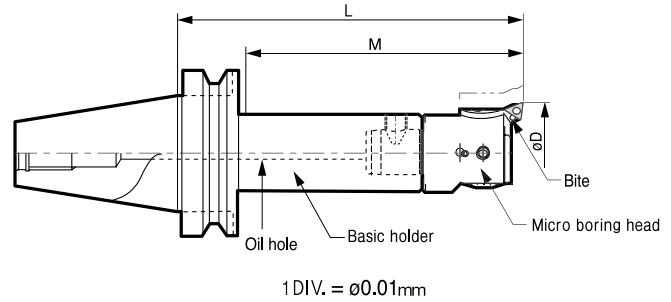

DINE Inc.

DIN69871 (MD-FBH Series) Micro Boring System

Order Code (Basic Holder & Head)	£	Boring Range $\varnothing D$		L	Max Boring Depth	Basic Holder	Micro Boring Head	Available Bites	kg
		Min	Max						
SK40-FBH20-113	£476.00	20	26	113	78	SK40-MD19F-80	FBH1920N	FBB20N-C	1.5
SK40-FBH26-117	£500.00	26	34	117	82	SK40-MD25F-80	FBH2526N	FBB26N-C	1.7
SK40-FBH33-151	£526.00	33	43	151	116	SK40-MD32F-110	FBH3233N	FBB33N-C	2.1
SK40-FBH42-172	£580.00	42	54	172	127	SK40-MD40F-125	FBH4042N	FBB42N-C	2.0
SK40-FBH53-157	£619.00	53	70	157	122	SK40-MD50F-100	FBH5053N	FBB53N-C	2.2
SK40-FBH68-141	£692.00	68	100	141	106	SK40-MD63F-70	FBH6368N	FBB68N-C	4.1
SK40-FBH98-212	£861.00	98	150	212	177	SK40-MD63F-125	FBH6398N	FBB68N-C	4.2
SK50-FBH20-118	£479.00	20	26	118	83	SK50-MD19F-85	FBH1920N	FBB20N-C	5.2
SK50-FBH26-117	£512.00	26	34	117	82	SK50-MD25F-80	FBH2526N	FBB26N-C	5.5
SK50-FBH33-151	£540.00	33	43	151	116	SK50-MD32F-110	FBH3233N	FBB33N-C	6.0
SK50-FBH42-192	£598.00	42	54	182	157	SK50-MD40F-145	FBH4042N	FBB42N-C	6.3
SK50-FBH42-242	£607.00	42	54	242	207	SK50-MD40F-195	FBH4042N	FBB42N-C	6.6
SK50-FBH53-182	£634.00	53	70	182	147	SK50-MD50F-125	FBH5053N	FBB53N-C	6.9
SK50-FBH53-282	£656.00	53	70	282	247	SK50-MD50F-225	FBH5053N	FBB53N-C	7.2
SK50-FBH68-201	£701.00	68	100	201	166	SK50-MD63F-130	FBH6368N	FBB68N-C	8.1
SK50-FBH68-301	£728.00	68	100	301	266	SK50-MD63F-230	FBH6368N	FBB68N-C	8.5
SK50-FBH98-211	£868.00	98	150	211	176	SK50-MD63F-140	FBH6398N	FBB68N-C	8.9
SK50-FBH98-265	£885.00	98	150	265	231	SK50-MD63F-195	FBH6398N	FBB68N-C	9.4

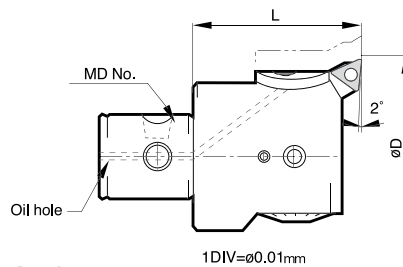

Micro Boring Heads (MD-FBH Series)

Order Code	£	Boring Range $\varnothing D$		L	Scale Ring 1Rev. Adjustable range	MD No	Bites	kg
		Min	Max					
FBH1920N	£341.00	20	26	33	$\varnothing 0.4$ mm	MD19 11	FBB20N-C	0.06
FBH2526N	£365.00	26	34	37.5	$\varnothing 0.4$ mm	MD25 14	FBB26N-C	0.12
FBH3233N	£388.00	33	43	41	$\varnothing 0.5$ mm	MD32 18	FBB33N-C	0.24
FBH4042N	£419.00	42	54	47	$\varnothing 0.5$ mm	MD40 22	FBB42N-C	0.41
FBH5053N	£459.00	53	70	57	$\varnothing 0.6$ mm	MD50 28	FBB53N-C	0.8
FBH6368N	£508.00	68	100	71	$\varnothing 0.8$ mm	MD63 36	FBB68N-C	1.7
FBH6398N	£674.00	98	150	71	$\varnothing 0.8$ mm	MD63 36	FBB68N-C	2.35



MODULAR BT MAS Basic Holders (MD Series)

For Use With Micro boring Systems (FBH Series) & Twin Cut Balanced Tools (DBC Series)

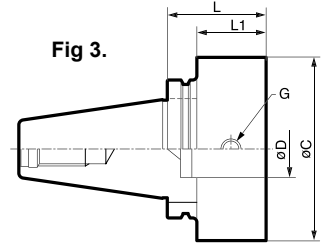
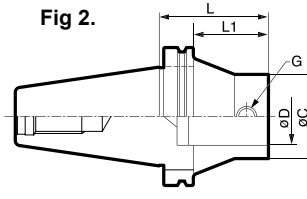
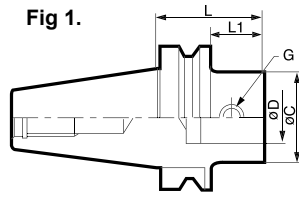

BT MAS - Basic Holder (MD Series)

Order Code (Basic Body)	£	MD No	ØC	ØD	L	L1	G	KG	Fig
BT40-MD19F-70	£89.00	MD1911	19	11	70	43	M5	1.8	1
BT40-MD25F-95	£89.00	MD2514	25	14	95	68	M6	1.9	1
BT40-MD25F-105R	£90.00	MD2514	25	14	105	78	M6	1.9	1
BT40-MD32F-100	£92.00	MD3218	32	18	100	73	M8	2.3	1
BT40-MD32F-115R	£94.00	MD3218	32	18	115	88	M8	2.4	1
BT40-MD40F-60	£94.00	MD4022	40	22	60	33	M10	2.7	2
BT40-MD40F-110R	£107.00	MD4022	40	22	110	83	M10	2.7	2
BT40-MD40F-115	£110.00	MD4022	40	22	115	88	M10	2.7	1
BT40-MD50F-100R	£110.00	MD5028	50	28	100	73	M12	2.7	2
BT40-MD50F-105	£110.00	MD5028	50	28	105	78	M12	2.7	1
BT40-MD63F-64	£122.00	MD6336	63	36	64	37	M16	3.3	3
BT40-MD63F-90	£125.00	MD6336	63	36	90	63	M16	3.6	3
BT40-MD63F-110	£129.00	MD6336	63	36	110	83	M16	4.6	3
BT40-MD63F-135	£132.00	MD6336	63	36	135	108	M16	4.7	3
BT40-MD80F-100	£132.00	MD8045	80	45	100	73	M16	4.8	3
BT50-MD19F-85	£92.00	MD1911	19	11	85	47	M5	4.3	1
BT50-MD19F-100	£92.00	MD1911	19	11	100	62	M5	4.3	1
BT50-MD25F-55	£99.00	MD2514	25	14	55	17	M6	4.3	1
BT50-MD25F-105	£101.00	MD2514	25	14	105	67	M6	4.5	1
BT50-MD25F-120R	£103.00	MD2514	25	14	120	82	M6	4.7	2
BT50-MD32F-110	£107.00	MD3218	32	18	110	72	M8	5.1	1
BT50-MD32F-115R	£107.00	MD3218	32	18	115	77	M8	5.1	2
BT50-MD32F-235R	£138.00	MD3218	32	18	235	148	M8	5.1	2
BT50-MD40F-60	£120.00	MD4022	40	22	60	22	M10	5	1
BT50-MD40F-125R	£121.00	MD4022	40	22	125	87	M10	5.1	1
BT50-MD40F-145	£129.00	MD4022	40	22	230	107	M10	5.1	1
BT50-MD50F-70	£125.00	MD5028	50	28	70	22	M12	5.6	1
BT50-MD50F-125	£125.00	MD5028	50	28	125	87	M12	6	1
BT50-MD50F-160R	£124.00	MD5028	50	28	160	122	M12	6.2	1
BT50-MD50F-225	£147.00	MD5028	50	28	225	187	M12	8.4	1
BT50-MD50F-250R	£156.00	MD5028	50	28	250	212	M12	6.5	2
BT50-MD63F-75	£131.00	MD6336	63	36	75	37	M12	6.8	1
BT50-MD63F-130	£138.00	MD6336	63	36	130	92	M16	6	1
BT50-MD63F-140	£139.00	MD6336	63	36	140	92	M16	6	1
BT50-MD63F-140R	£139.00	MD6336	63	36	140	102	M16	6	2
BT50-MD63F-195	£156.00	MD6336	63	36	195	157	M16	8	1
BT50-MD63F-230	£165.00	MD6336	63	36	230	192	M16	8.4	1
BT50-MD63F-240R	£151.00	MD6336	63	36	240	202	M16	8.4	2
BT50-MD80F-75	£139.00	MD8045	80	45	75	37	M16	9.1	1
BT50-MD80F-110	£146.00	MD8045	80	45	110	72	M16	9.4	1
BT50-MD80F-175	£165.00	MD8045	80	45	175	137	M16	9.5	1
BT50-MD90F-75	£147.00	MD9045	90	45	75	37	M16	9.8	1
BT50-MD90F-145	£161.00	MD9045	90	45	145	107	M16	10.2	1
BT50-MD90F-195	£175.00	MD9045	90	45	195	157	M16	10.4	1

DIN69871 Basic Holders (MD Series) MODULAR



For Use With Micro boring Systems (FBH Series) & Twin Cut Balanced Tools (DBC Series)

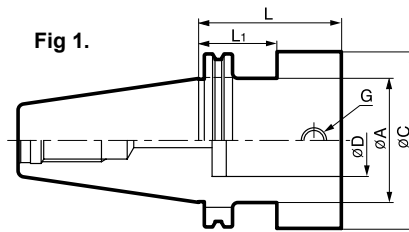
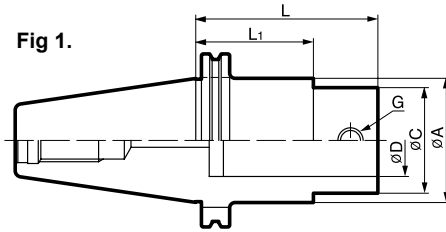

SK DIN69871 - Basic Holder (MD Series)

Order Code (Basic Body)	£	MD No	ØC	ØD	ØA	L	L1	G	KG	Fig
SK40-MD19F-80	£89.00	MD1911	19	11	50	80	35	M5	1.8	1
SK40-MD25F-80	£89.00	MD2514	25	14	50	80	36	M6	1.8	1
SK40-MD25F-105	£90.00	MD2514	25	14	50	105	36	M6	1.9	1
SK40-MD32F-85	£90.00	MD3218	32	18	50	85	36	M8	2	1
SK40-MD32F-115	£92.00	MD3218	32	18	50	115	36	M8	2.3	1
SK40-MD40F-60	£94.00	MD4022	40	22	50	60	36	M10	2.4	1
SK40-MD40F-100	£107.00	MD4022	40	22	50	100	36	M10	2.4	1
SK40-MD40F-125	£108.00	MD4022	40	22	50	125	36	M10	2.7	1
SK40-MD50F-75	£109.00	MD5028	50	28	50	75	36	M12	2.2	2
SK40-MD50F-100	£107.00	MD5028	50	28	50	100	36	M12	2.2	2
SK40-MD63F-70	£124.00	MD6336	63	36	50	70	36	M16	3.3	2
SK50-MD19F-85	£92.00	MD1911	19	11	80	85	36	M5	4.2	1
SK50-MD25F-80	£99.00	MD2514	25	14	80	80	36	M6	4.3	1
SK50-MD25F-105	£101.00	MD2514	25	14	80	105	36	M6	4.7	1
SK50-MD32F-85	£105.00	MD3218	32	18	80	85	36	M8	4.8	1
SK50-MD32F-110	£107.00	MD3218	32	18	80	110	36	M8	5.1	1
SK50-MD32F-155	£110.00	MD3218	32	18	80	155	36	M8	5.3	1
SK50-MD40F-100	£122.00	MD4022	40	22	80	100	36	M10	5.2	1
SK50-MD40F-145	£129.00	MD4022	40	22	80	145	36	M10	5.3	1
SK50-MD40F-195	£138.00	MD4022	40	22	80	195	36	M10	5.4	1
SK50-MD40F-220	£144.00	MD4022	40	22	80	220	36	M10	5.5	1
SK50-MD50F-100	£123.00	MD5028	50	28	80	100	36	M12	5.8	1
SK50-MD50F-125	£125.00	MD5028	50	28	80	125	36	M12	6.1	1
SK50-MD50F-225	£147.00	MD5028	50	28	80	225	36	M12	6.6	1
SK50-MD50F-240	£154.00	MD5028	50	28	80	240	36	M12	6.8	1
SK50-MD63F-75	£131.00	MD6336	63	36	80	75	36	M16	5.6	1
SK50-MD63F-110	£135.00	MD6336	63	36	80	110	36	M16	5.8	1
SK50-MD63F-130	£138.00	MD6336	63	36	80	130	36	M16	5.8	1
SK50-MD63F-140	£139.00	MD6336	63	36	80	140	36	M16	6	1
SK50-MD63F-195	£156.00	MD6336	63	36	80	195	36	M16	8	1
SK50-MD63F-230	£165.00	MD6336	63	36	80	230	36	M16	8.3	1
SK50-MD80F-95	£143.00	MD8045	80	45	80	95	36	M16	9.2	2
SK50-MD80F-150	£162.00	MD8045	80	45	80	150	36	M16	9.5	2
SK50-MD90F-75	£147.00	MD9045	90	45	80	75	36	M16	9.3	2
SK50-MD90F-115	£158.00	MD9045	90	45	80	115	36	M16	10.1	2
SK50-MD90F-165	£171.00	MD9045	90	45	80	165	36	M16	10.3	2

MD Series Holders - Suitable for all the heads below.....





MODULAR Extension Bar (MD-EXT Series)

For Use With Micro boring Systems (FBH Series) & Twin Cut Balanced Tools (DBC Series) & MD Series (BT MAS or DIN69871) Basic Toolholders

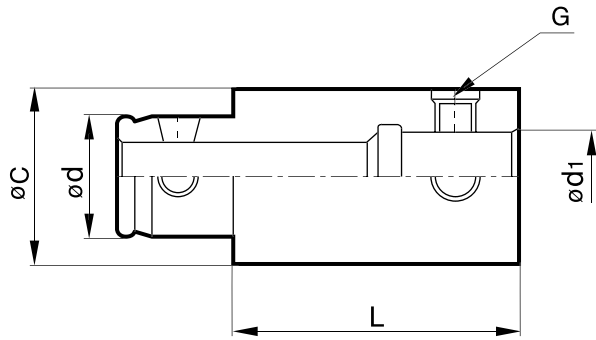

- For extending reach length on MD Modular systems
- Special design cone locking screw for fast and accurate setting
- High accuracy assembly (error less than 5µm)

Extension Bar (EXT Series)

Order Code	£	MD No.	ØC	Ød	L	Ød1	G
EXT1930F	£44.00	MD1911	19	11	30	11	M5
EXT1950F	£44.00	MD1911	19	11	50	11	M5
EXT2530F	£46.00	MD2514	25	14	30	14	M6
EXT2550F	£52.00	MD2514	25	14	50	14	M6
EXT3235F	£52.00	MD3218	32	18	35	18	M8
EXT3260F	£52.00	MD3218	32	18	60	18	M8
EXT4040F	£52.00	MD4022	40	22	40	22	M10
EXT4090F	£55.00	MD4022	40	22	90	22	M12
EXT5050F	£55.00	MD5028	50	28	50	28	M12
EXT50100F	£61.00	MD5028	50	28	100	28	M12
EXT6360F	£55.00	MD6336	63	36	60	36	M16
EXT63120F	£61.00	MD6336	63	36	120	36	M16
EXT8070F	£78.00	MD8045	80	45	70	45	M16
EXT80120F	£84.00	MD8045	80	45	120	45	M16
EXT9080F	£95.00	MD9045	90	45	80	45	M16
EXT90130F	£95.00	MD9045	90	45	130	45	M16

Reduction Bar (MD-RDC Series) MODULAR



For Use With Micro boring Systems (FBH Series) & Twin Cut Balanced Tools (DBC Series)
& MD Series (BT MAS or DIN69871) Basic Toolholders

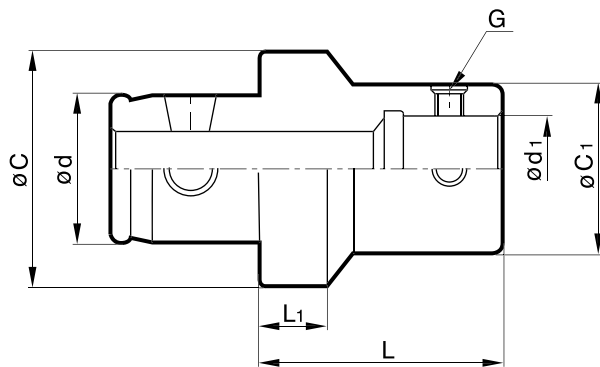

DINE Inc.

- For extending reach length on MD Modular systems.
- For reducing from a larger tool holder to a smaller head
- Special design cone locking screw for fast and accurate setting
- High accuracy assembly (error less than 5µm)

Reduction Bar (RDC Series)

Order Code	£	Ød	MD No. Back	MD No. Front	ØC1	Ød1	ØC	L	L1	G
RDC3225F	£66.00	18	MD3218	MD2514	25	14	32	30	9	M6
RDC4025F	£66.00	22	MD4022	MD2514	25	14	40	30	9	M6
RDC4032F	£66.00	22	MD4022	MD3218	32	18	40	30	9	M8
RDC5025F	£66.00	28	MD5028	MD2514	25	14	50	30	9	M6
RDC5032F	£66.00	28	MD5028	MD3218	32	18	50	30	9	M8
RDC5040F	£66.00	28	MD5028	MD4022	40	22	50	40	10	M10
RDC6325F	£77.00	36	MD6336	MD2514	25	14	63	30	9	M6
RDC6332F	£77.00	36	MD6336	MD3218	32	18	63	30	9	M8
RDC6340F	£77.00	36	MD6336	MD4022	40	22	63	40	10	M10
RDC6350F	£77.00	36	MD6336	MD5028	50	28	63	45	10	M12
RDC8032F	£88.00	45	MD8045	MD3218	32	18	80	30	9	M6
RDC8040F	£88.00	45	MD8045	MD4022	40	22	80	40	10	M10
RDC8050F	£88.00	45	MD8045	MD5028	50	28	80	45	10	M12
RDC8063F	£88.00	45	MD8045	MD6336	63	36	80	50	13	M16

Spindle Tooling

Dinox Modular

Angle Heads

VDI Tooling

Driven Tooling

Vices & Clamps

HSK ICTM