

SVHCR/L TURNING TOOL

Order Code	£	HSK (d1)	l	f	r	Inserts	Shim	Shim Pin	Screw
H32CSVHCR/L11*	£92.00	32	40	22	0.4	VC..1103..	-	-	TR1
H40ASVHCR/L11	£92.00	40	50	27	0.4	VC..1103..	-	-	TR1
H40ASVHCR/L16	£92.00	40	55	27	0.8	VC..1604..	SPVC16	VTA02	TR8
H50ASVHCR/L11	£117.00	50	60	35	0.4	VC..1103..	-	-	TR1
H50ASVHCR/L16	£117.00	50	60	35	0.8	VC..1604..	SPVC16	VTA02	TR8
H63ASVHCR/L11	£130.00	63	70	45	0.4	VC..1103..	-	-	TR1
H63ASVHCR/L16	£130.00	63	70	45	0.8	VC..1604..	SPVC16	VTA02	TR8

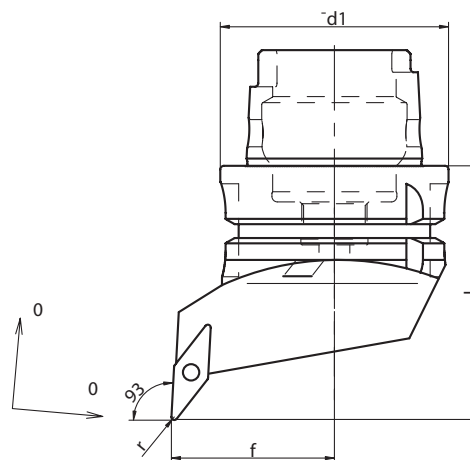

SVJCR/L TURNING TOOL

Order Code	£	HSK (d1)	l	f	r	Inserts	Shim	Shim Pin	Screw
H32CSVJCR/L11*	£92.00	32	40	22	0.4	VC..1103..	-	-	TR1
H40ASVJCR/L11	£92.00	40	50	27	0.4	VC..1103..	-	-	TR1
H40ASVJCR/L16	£92.00	40	60	27	0.8	VC..1604..	SPVC16	VTA02	TR8
H50ASVJCR/L16	£117.00	50	70	35	0.8	VC..1604..	SPVC16	VTA02	TR8
H63ASVJCR/L16	£130.00	63	75	45	0.8	VC..1604..	SPVC16	VTA02	TR8
H100ASVJCR/L16	£192.00	100	90	65	0.8	VC..1604..	SPVC16	VTA02	TR8

Modular Adaptors (Page G5-G6)

