

Drill Head (MD-NPU) & Tap Head (MD-DTN) MODULAR

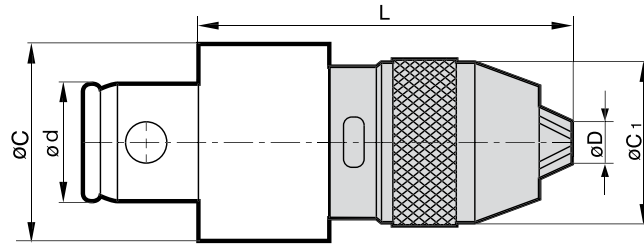

Modular Tooling Drill Chuck For Deep Pocket Drilling



DINE Inc.

- Modular Drill Chuck for deep pocket drilling.
- Unlimited length through use of extensions.
- Special design cone locking screw for fast and accurate setting.
- High accuracy assembly (error less than 5µm)

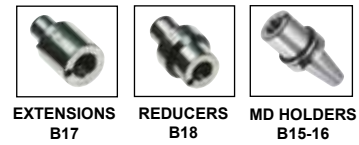

Drill Chuck Head (MD-NPU Series)

Order Code	£	Chucking Dia Range ØD		ØC	Ød	ØC1	L	MD No.
		Min	Max					
NPU 4008	£150.00	0	8	40	22	38	115	MD4022
NPU 5008	£150.00	0	8	50	28	38	115	MD5028
NPU 5013	£150.00	1	13	50	28	50	145	MD5028
NPU 6308	£150.00	0	8	63	36	38	115	MD6336
NPU 6313	£150.00	1	13	63	36	50	145	MD6336

Modular Tooling Quick Change Tap Chuck For Deep Pocket Tapping

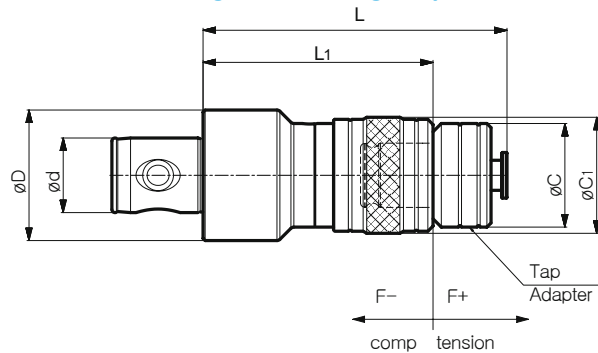

DINE Inc.

- Modular Drill Chuck for deep pocket drilling.
- Tension & compression
- Quick change system



Tap Chuck Head (MD-DTN Series)

Order Code	£	Tap Dia Range ØD		L	L1	ØD	Ød	ØC	ØC1	Insert		Tap Adaptor Size	MD No.
		Min	Max							F1	F+		
DTN 5012	£140.00	M3	M12	95	70	50	28	39	32	4	10	1	MD5028
DTN 5022	£170.00	M8	M22	145	111	50	28	56	50	12.5	12.5	2	MD5028
DTN 6312	£150.00	M3	M12	95	70	50	28	39	32	4	10	1	MD5028
DTN 6322	£180.00	M8	M22	145	111	50	28	56	50	12.5	12.5	2	MD5028
DTN 8038	£230.00	M16	M38	220	175	80	45	81	72	20	20	3	MD8045



MODULAR BT MAS Basic Holders (MD Series)

For Use With Microboring Systems (FBH Series) & Twin Cut Balanced Tools (DBC Series)

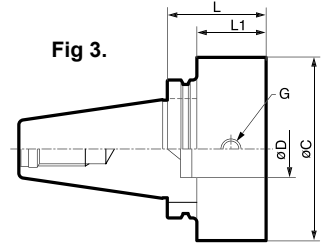
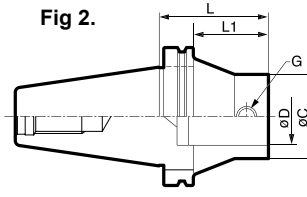
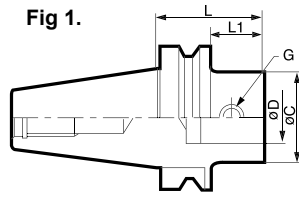

BT MAS - Basic Holder (MD Series)

Order Code (Basic Body)	£	MD No	ØC	ØD	L	L1	G	KG	Fig
BT40-MD19F-70	£89.00	MD1911	19	11	70	43	M5	1.8	1
BT40-MD25F-95	£89.00	MD2514	25	14	95	68	M6	1.9	1
BT40-MD25F-105R	£90.00	MD2514	25	14	105	78	M6	1.9	1
BT40-MD32F-100	£92.00	MD3218	32	18	100	73	M8	2.3	1
BT40-MD32F-115R	£94.00	MD3218	32	18	115	88	M8	2.4	1
BT40-MD40F-60	£94.00	MD4022	40	22	60	33	M10	2.7	2
BT40-MD40F-110R	£107.00	MD4022	40	22	110	83	M10	2.7	2
BT40-MD40F-115	£110.00	MD4022	40	22	115	88	M10	2.7	1
BT40-MD50F-100R	£110.00	MD5028	50	28	100	73	M12	2.7	2
BT40-MD50F-105	£110.00	MD5028	50	28	105	78	M12	2.7	1
BT40-MD63F-64	£122.00	MD6336	63	36	64	37	M16	3.3	3
BT40-MD63F-90	£125.00	MD6336	63	36	90	63	M16	3.6	3
BT40-MD63F-110	£129.00	MD6336	63	36	110	83	M16	4.6	3
BT40-MD63F-135	£132.00	MD6336	63	36	135	108	M16	4.7	3
BT40-MD80F-100	£132.00	MD8045	80	45	100	73	M16	4.8	3
BT50-MD19F-85	£92.00	MD1911	19	11	85	47	M5	4.3	1
BT50-MD19F-100	£92.00	MD1911	19	11	100	62	M5	4.3	1
BT50-MD25F-55	£99.00	MD2514	25	14	55	17	M6	4.3	1
BT50-MD25F-105	£101.00	MD2514	25	14	105	67	M6	4.5	1
BT50-MD25F-120R	£103.00	MD2514	25	14	120	82	M6	4.7	2
BT50-MD32F-110	£107.00	MD3218	32	18	110	72	M8	5.1	1
BT50-MD32F-115R	£107.00	MD3218	32	18	115	77	M8	5.1	2
BT50-MD32F-235R	£138.00	MD3218	32	18	235	148	M8	5.1	2
BT50-MD40F-60	£120.00	MD4022	40	22	60	22	M10	5	1
BT50-MD40F-125R	£121.00	MD4022	40	22	125	87	M10	5.1	1
BT50-MD40F-145	£129.00	MD4022	40	22	230	107	M10	5.1	1
BT50-MD50F-70	£125.00	MD5028	50	28	70	22	M12	5.6	1
BT50-MD50F-125	£125.00	MD5028	50	28	125	87	M12	6	1
BT50-MD50F-160R	£124.00	MD5028	50	28	160	122	M12	6.2	1
BT50-MD50F-225	£147.00	MD5028	50	28	225	187	M12	8.4	1
BT50-MD50F-250R	£156.00	MD5028	50	28	250	212	M12	6.5	2
BT50-MD63F-75	£131.00	MD6336	63	36	75	37	M12	6.8	1
BT50-MD63F-130	£138.00	MD6336	63	36	130	92	M16	6	1
BT50-MD63F-140	£139.00	MD6336	63	36	140	92	M16	6	1
BT50-MD63F-140R	£139.00	MD6336	63	36	140	102	M16	6	2
BT50-MD63F-195	£156.00	MD6336	63	36	195	157	M16	8	1
BT50-MD63F-230	£165.00	MD6336	63	36	230	192	M16	8.4	1
BT50-MD63F-240R	£151.00	MD6336	63	36	240	202	M16	8.4	2
BT50-MD80F-75	£139.00	MD8045	80	45	75	37	M16	9.1	1
BT50-MD80F-110	£146.00	MD8045	80	45	110	72	M16	9.4	1
BT50-MD80F-175	£165.00	MD8045	80	45	175	137	M16	9.5	1
BT50-MD90F-75	£147.00	MD9045	90	45	75	37	M16	9.8	1
BT50-MD90F-145	£161.00	MD9045	90	45	145	107	M16	10.2	1
BT50-MD90F-195	£175.00	MD9045	90	45	195	157	M16	10.4	1

DIN69871 Basic Holders (MD Series) MODULAR



For Use With Microboring Systems (FBH Series) & Twin Cut Balanced Tools (DBC Series)

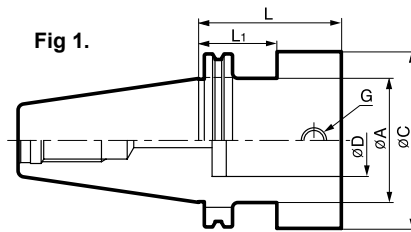
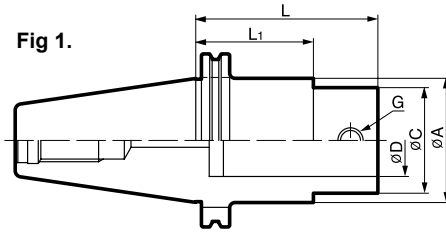

SK DIN69871 - Basic Holder (MD Series)

Order Code (Basic Body)	£	MD No	ØC	ØD	ØA	L	L1	G	KG	Fig
SK40-MD19F-80	£89.00	MD1911	19	11	50	80	35	M5	1.8	1
SK40-MD25F-80	£89.00	MD2514	25	14	50	80	36	M6	1.8	1
SK40-MD25F-105	£90.00	MD2514	25	14	50	105	36	M6	1.9	1
SK40-MD32F-85	£90.00	MD3218	32	18	50	85	36	M8	2	1
SK40-MD32F-115	£92.00	MD3218	32	18	50	115	36	M8	2.3	1
SK40-MD40F-60	£94.00	MD4022	40	22	50	60	36	M10	2.4	1
SK40-MD40F-100	£107.00	MD4022	40	22	50	100	36	M10	2.4	1
SK40-MD40F-125	£108.00	MD4022	40	22	50	125	36	M10	2.7	1
SK40-MD50F-75	£109.00	MD5028	50	28	50	75	36	M12	2.2	2
SK40-MD50F-100	£107.00	MD5028	50	28	50	100	36	M12	2.2	2
SK40-MD63F-70	£124.00	MD6336	63	36	50	70	36	M16	3.3	2
SK50-MD19F-85	£92.00	MD1911	19	11	80	85	36	M5	4.2	1
SK50-MD25F-80	£99.00	MD2514	25	14	80	80	36	M6	4.3	1
SK50-MD25F-105	£101.00	MD2514	25	14	80	105	36	M6	4.7	1
SK50-MD32F-85	£105.00	MD3218	32	18	80	85	36	M8	4.8	1
SK50-MD32F-110	£107.00	MD3218	32	18	80	110	36	M8	5.1	1
SK50-MD32F-155	£110.00	MD3218	32	18	80	155	36	M8	5.3	1
SK50-MD40F-100	£122.00	MD4022	40	22	80	100	36	M10	5.2	1
SK50-MD40F-145	£129.00	MD4022	40	22	80	145	36	M10	5.3	1
SK50-MD40F-195	£138.00	MD4022	40	22	80	195	36	M10	5.4	1
SK50-MD40F-220	£144.00	MD4022	40	22	80	220	36	M10	5.5	1
SK50-MD50F-100	£123.00	MD5028	50	28	80	100	36	M12	5.8	1
SK50-MD50F-125	£125.00	MD5028	50	28	80	125	36	M12	6.1	1
SK50-MD50F-225	£147.00	MD5028	50	28	80	225	36	M12	6.6	1
SK50-MD50F-240	£154.00	MD5028	50	28	80	240	36	M12	6.8	1
SK50-MD63F-75	£131.00	MD6336	63	36	80	75	36	M16	5.6	1
SK50-MD63F-110	£135.00	MD6336	63	36	80	110	36	M16	5.8	1
SK50-MD63F-130	£138.00	MD6336	63	36	80	130	36	M16	5.8	1
SK50-MD63F-140	£139.00	MD6336	63	36	80	140	36	M16	6	1
SK50-MD63F-195	£156.00	MD6336	63	36	80	195	36	M16	8	1
SK50-MD63F-230	£165.00	MD6336	63	36	80	230	36	M16	8.3	1
SK50-MD80F-95	£143.00	MD8045	80	45	80	95	36	M16	9.2	2
SK50-MD80F-150	£162.00	MD8045	80	45	80	150	36	M16	9.5	2
SK50-MD90F-75	£147.00	MD9045	90	45	80	75	36	M16	9.3	2
SK50-MD90F-115	£158.00	MD9045	90	45	80	115	36	M16	10.1	2
SK50-MD90F-165	£171.00	MD9045	90	45	80	165	36	M16	10.3	2

MD Series Holders - Suitable for all the heads below.....





MODULAR Extension Bar (MD-EXT Series)

For Use With Microboring Systems (FBH Series) & Twin Cut Balanced Tools (DBC Series) & MD Series (BT MAS or DIN69871) Basic Toolholders

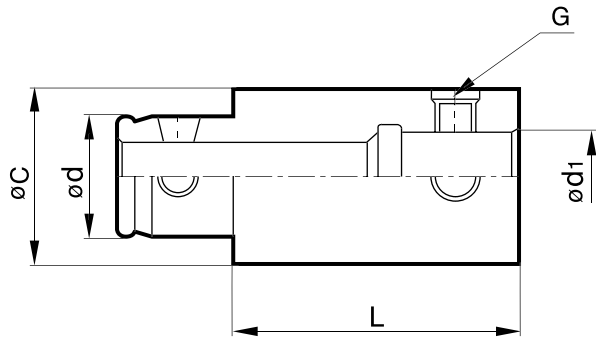

- For extending reach length on MD Modular systems
- Special design cone locking screw for fast and accurate setting
- High accuracy assembly (error less than 5µm)

Extension Bar (EXT Series)

Order Code	£	MD No.	ØC	Ød	L	Ød1	G
EXT1930F	£44.00	MD1911	19	11	30	11	M5
EXT1950F	£44.00	MD1911	19	11	50	11	M5
EXT2530F	£46.00	MD2514	25	14	30	14	M6
EXT2550F	£52.00	MD2514	25	14	50	14	M6
EXT3235F	£52.00	MD3218	32	18	35	18	M8
EXT3260F	£52.00	MD3218	32	18	60	18	M8
EXT4040F	£52.00	MD4022	40	22	40	22	M10
EXT4090F	£55.00	MD4022	40	22	90	22	M12
EXT5050F	£55.00	MD5028	50	28	50	28	M12
EXT50100F	£61.00	MD5028	50	28	100	28	M12
EXT6360F	£55.00	MD6336	63	36	60	36	M16
EXT63120F	£61.00	MD6336	63	36	120	36	M16
EXT8070F	£78.00	MD8045	80	45	70	45	M16
EXT80120F	£84.00	MD8045	80	45	120	45	M16
EXT9080F	£95.00	MD9045	90	45	80	45	M16
EXT90130F	£95.00	MD9045	90	45	130	45	M16

Reduction Bar (MD-RDC Series) MODULAR



For Use With Microboring Systems (FBH Series) & Twin Cut Balanced Tools (DBC Series)
& MD Series (BT MAS or DIN69871) Basic Toolholders

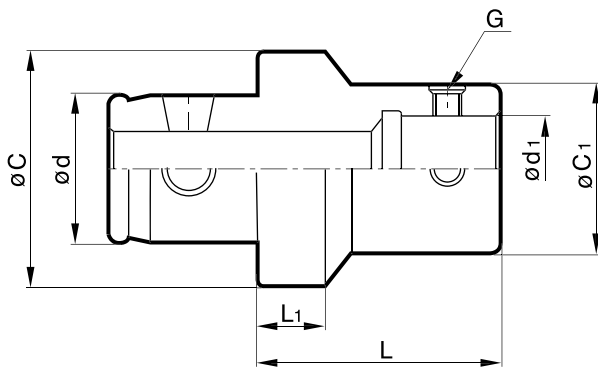

DINE Inc.

- For extending reach length on MD Modular systems.
- For reducing from a larger tool holder to a smaller head
- Special design cone locking screw for fast and accurate setting
- High accuracy assembly (error less than 5µm)

Reduction Bar (RDC Series)

Order Code	£	Ød	MD No. Back	MD No. Front	ØC1	Ød1	ØC	L	L1	G
RDC3225F	£66.00	18	MD3218	MD2514	25	14	32	30	9	M6
RDC4025F	£66.00	22	MD4022	MD2514	25	14	40	30	9	M6
RDC4032F	£66.00	22	MD4022	MD3218	32	18	40	30	9	M8
RDC5025F	£66.00	28	MD5028	MD2514	25	14	50	30	9	M6
RDC5032F	£66.00	28	MD5028	MD3218	32	18	50	30	9	M8
RDC5040F	£66.00	28	MD5028	MD4022	40	22	50	40	10	M10
RDC6325F	£77.00	36	MD6336	MD2514	25	14	63	30	9	M6
RDC6332F	£77.00	36	MD6336	MD3218	32	18	63	30	9	M8
RDC6340F	£77.00	36	MD6336	MD4022	40	22	63	40	10	M10
RDC6350F	£77.00	36	MD6336	MD5028	50	28	63	45	10	M12
RDC8032F	£88.00	45	MD8045	MD3218	32	18	80	30	9	M6
RDC8040F	£88.00	45	MD8045	MD4022	40	22	80	40	10	M10
RDC8050F	£88.00	45	MD8045	MD5028	50	28	80	45	10	M12
RDC8063F	£88.00	45	MD8045	MD6336	63	36	80	50	13	M16

Spindle Tooling

Dinox Modular

Angle Heads

VDI Tooling

Driven Tooling

Vices & Clamps

HSK ICTM