

### 2 FLUTE 90° SOLID CARBIDE DRILL MILL

Plain Shank 'For chamfering, drilling, slotting, spotting & profiling'

Series E5400

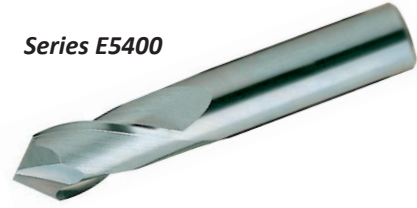
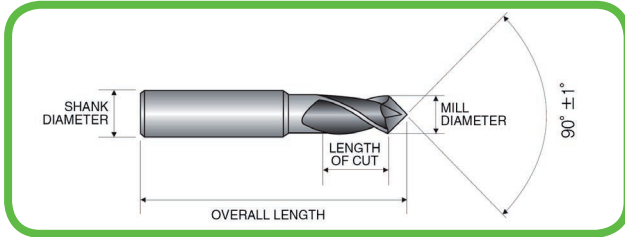

MICROGRAIN  
SOLID  
CARBIDE

90°

Cutting  
Data  
C7

Diameter	Shank	Flute Length	Overall Length	Order Code	£
3	4	6	50	E5400030	£14.44
4	5	8	50	E5400040	£14.98
5	6	10	50	E5400050	£17.13
6	8	12	60	E5400060	£19.27
8	10	16	70	E5400080	£26.74
10	12	18	70	E5400100	£33.73
12	12	20	70	E5400120	£33.73
16	16	26	80	E5400160	£48.17
20	20	32	100	E5400200	£85.10

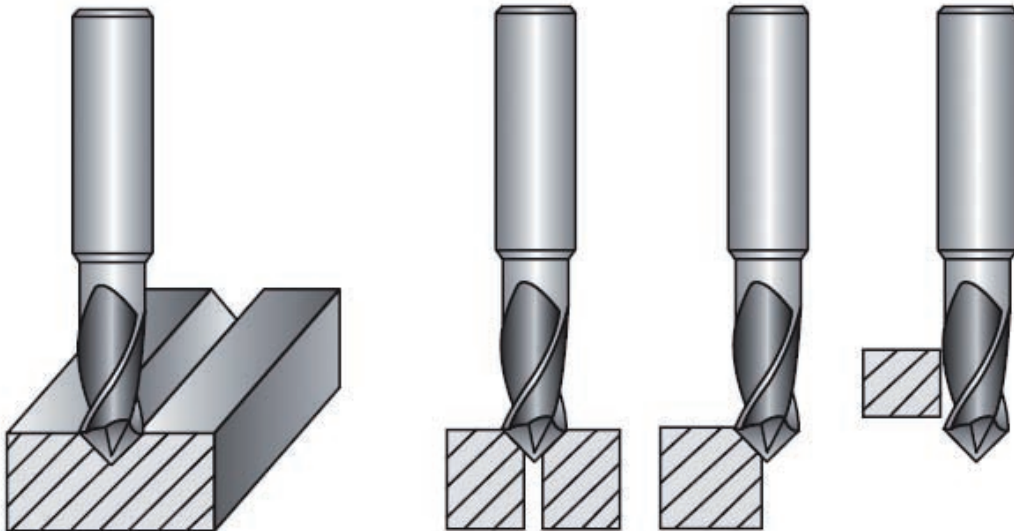

### 2 FLUTE SOLID CARBIDE CHAMFERING

(Series E5400)

MATERIAL	CARBON STEELS ALLOY STEELS TOOL STEELS		CARBON STEELS ALLOY STEELS TOOL STEELS		CARBON STEELS ALLOY STEELS TOOL STEELS		STAINLESS STEELS TITANIUM ALLOYS		ALUMINIUM ALLOYS	
HARDNESS	~ HRC20		HRC20 ~ HRC30		HRC30 ~ HRC40					
STRENGTH	500 ~ 800N/mm2		800 ~ 1000N/mm2		1000 ~ 1300N/mm2					
DIAMETER	RPM	FEED	RPM	FEED	RPM	FEED	RPM	FEED	RPM	FEED
3	4400	220	3500	160	3000	140	2400	100	11000	550
4	3600	220	3000	160	2500	140	2000	100	9000	580
5	2860	230	2400	170	2000	140	1760	105	6900	620
6	2300	240	2000	170	1600	140	1400	105	5600	640
8	1760	250	1540	180	1200	145	1000	110	4400	660
10	1500	250	1300	190	1100	145	870	110	4000	680
12	1300	260	1100	200	900	150	730	115	3500	700
16	1000	250	950	200	700	160	550	120	2750	740
20	950	260	750	210	600	160	530	130	2200	770

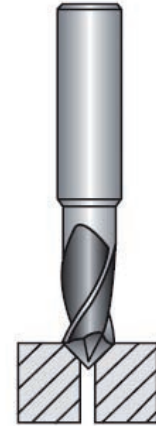

### 2 FLUTE SOLID CARBIDE CHAMFERING & SIDE CUTTING

(Series E5400)

MATERIAL	CARBON STEELS ALLOY STEELS TOOL STEELS		CARBON STEELS ALLOY STEELS TOOL STEELS		CARBON STEELS ALLOY STEELS TOOL STEELS		STAINLESS STEELS TITANIUM ALLOYS		ALUMINIUM ALLOYS	
HARDNESS	~ HRC20		HRC20 ~ HRC30		HRC30 ~ HRC40					
STRENGTH	500 ~ 800N/mm2		800 ~ 1000N/mm2		1000 ~ 1300N/mm2					
DIAMETER	RPM	FEED	RPM	FEED	RPM	FEED	RPM	FEED	RPM	FEED
3	5900	95	3900	65	3300	50	2400	40	14000	230
4	4800	95	3200	65	2800	50	2000	40	12000	240
5	3800	100	2500	65	2200	55	1760	45	9500	250
6	3000	110	2000	70	1800	60	1400	50	7700	300
8	2300	115	1540	75	1300	65	1100	55	5800	350
10	2000	120	1300	80	1200	65	1000	55	5100	380
12	1760	130	1100	90	1000	70	840	60	4400	400
16	1300	140	900	90	770	70	660	60	3300	330
20	1100	140	700	90	600	70	440	60	2640	340

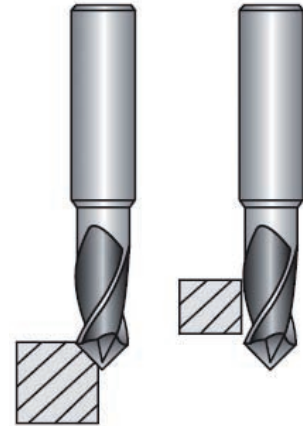

### 2 FLUTE SOLID CARBIDE V-GROOVING

(Series E5400)

MATERIAL	CARBON STEELS ALLOY STEELS TOOL STEELS		CARBON STEELS ALLOY STEELS TOOL STEELS		CARBON STEELS ALLOY STEELS TOOL STEELS		STAINLESS STEELS TITANIUM ALLOYS		ALUMINIUM ALLOYS	
HARDNESS	~ HRC20		HRC20 ~ HRC30		HRC30 ~ HRC40					
STRENGTH	500 ~ 800N/mm2		800 ~ 1000N/mm2		1000 ~ 1300N/mm2					
DIAMETER	RPM	FEED	RPM	FEED	RPM	FEED	RPM	FEED	RPM	FEED
3	5900	60	4000	30	3300	25	2400	20	14000	220
4	4800	60	3300	30	2800	25	2000	20	11800	230
5	3800	60	2500	30	2200	25	1760	20	9500	240
6	3000	60	2000	30	1800	30	1400	20	7700	250
8	2300	65	1540	35	1300	35	1100	20	5800	260
10	2000	65	1300	35	1200	35	1000	20	5000	260
12	1760	65	1000	40	1000	35	840	20	4400	260
16	1400	65	900	40	770	35	660	25	3300	270
20	1100	65	700	40	600	35	440	25	2600	270

